



Dual Pump Protection and Control Module Professional Series

BIA-nXt-DPC 1-22 Pro

PN 811363

BIA-nXt-DPC 1-22 Pro S/S

PN 811368

Installation and Operation Manual



A. Shortcuts

Switching between AUTO and MANUAL:

PRESS and release the **MODE** button

Note: All pump protections are valid in MANUAL state

Switching to Manual (controller in LOCK MODE)

Lock parameter # 017 Pg 18

PRESS and HOLD the **MODE** button for 5 seconds

User Programming menu

Parameter 021 onwards
In manual mode, press and hold **STORE/SET** for 5 sec
Page 18

Expert Programming menu

Parameter 003 onwards
In manual mode, press the **STORE/SET** then the **MODE** button and hold both for 5 sec.
Page 16

Programming:

A-START increases a value

A-STOP decreases a value

Short press **STORE/SET** to store a value and advance to the next parameter

Press **MODE** to save changes and exit

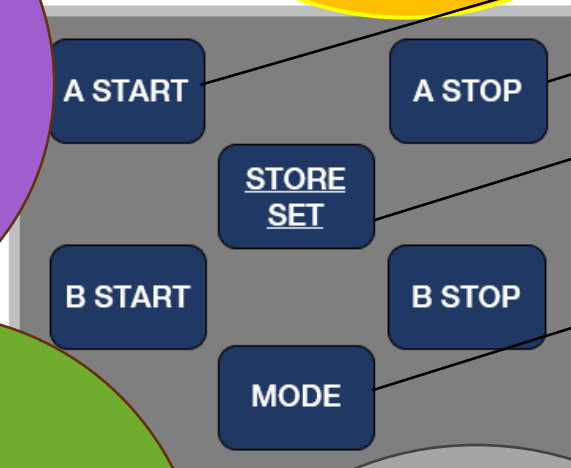

Increase a value

Decrease a value

Save value and proceed to next parameter

Store all and exit

Single Phase DPC-1

Set Parameter 007: OFF
Set Parameter 008: OFF
Set Parameter 013: Minimum 1 sec
Set Parameter 026: OFF

B. Shortcuts cont

Auto pump calibration

Set controller to MANUAL mode.

Short press **A-START** or **B-START**

Allow the pump to run and the current draw to stabilise.

Once you are satisfied the pump is in its 'normal' operating range, short press **STORE/SET**

The controller will monitor for 3 sec then chirp and store the calibration value.

The controller display will indicate if a pump does not have a calibration value stored.

The controller calibration value can be checked and adjusted from the User Menu

Pump A = parameter #021

Pump B = parameter #022

Manual calibration

Set controller to MANUAL mode.

Press and hold **STORE/SET** for 5 sec

Enter the desired calibration value

Pump A = parameter #021

Press **STORE/SET** to advance to the next parameter

Pump B = parameter #022

Press **MODE** to save and exit

Error log:

Switch to MANUAL mode
Ensure no pumps are running.
PRESS and HOLD the **A -STOP**
or the **B -STOP** button, then
SHORT PRESS the **MODE**
button
Press **MODE** to scroll
Press **A-STOP** to exit

A START

A STOP

STORE
SET

B START

B STOP

MODE

To clear a pump calibration

With controller in MANUAL mode and the pump stopped, PRESS and HOLD either **A-STOP** or the **B-STOP** button for 5 seconds.

The display will show that the pump has no calibration stored

Accumulated Run time:

Controller in manual state.

Press and hold **STORE/SET**

Press **A-STOP** or **B-STOP** to see the run time

1. Introduction

Bianco nXt-DPC Pro Dual Pump Logic Control and Protection panel is intended for use in industries which require a which require a pump controller in a secure, professional quality, metal enclosure.

nXt DPC-1 panels are designed to control and protect dual single phase pumps. The user can configure the control inputs to suit their application and enjoy the benefits of superior control logic and pump protection. With a choice of powder coated or stainless steel, the robust, lockable enclosure is weather proof and tamper proof.

There are 3 primary control logic modes:







- ‘Drainage’ where control is concentrated at the source
- ‘Boosting’ which references pressure switching on the delivery side for control
- ‘Transfer’ which is a mix of source and destination control

nXt-DPC is equipped with a RS485 modbus interface to connect to a BMS. The LCD screen displays the pump running state and provides the user a wealth of useful information.

The controller is easy to set up with an initial push button calibration and individual parameters can be fine-tuned.





A nXt-DPC Pro controller is particularly useful where there is the need to control and protect pump installations managing the automatic operation through a variety of switching methods without the need to create a bespoke control solution.

2. Warnings and Cautions

	Read the manual carefully before starting
	Prior to starting installation or maintenance the controller must be disconnected from the power supply.
	Any changes or modification to the wiring must be carried out by competent, skilled and suitably qualified personnel only.
	A qualified electrician should correctly size and install circuit breakers to protect the power supply. The fitment of additional surge protection is recommended as good practice.
	Never open the cover while controller is connected to electrical supply. Disconnect and allow the internal electronics to discharge before opening the cover
	This appliance is not intended for use by persons (including children) with reduced physical, sensory or mental capabilities, or lack of experience and knowledge, unless they have been given supervision or instruction concerning use of the appliance by a person responsible for their safety. Children should be supervised to ensure that they do not play with the appliance.
	Ensure the controller is a suitable size for the pump motor (see Section 5, Page 6: Technical Data). Size according to full load current amperage.

3. Contents

- A. Shortcuts 2 - 3**
- 1. Introduction 4**
- 4. Technical Specifications..... 6**
- 5. Display 7 - 8**
- Logic explanations for Modes 00 - 06 9 - 12**
- 6. Electrical Connections..... 13**
- 7. Modbus 15**
- 8. Parameter Calibration..... 16**
- 9. Program Parameters 16**
- 10. Quick guide: Drainage Mode, floats connected to control..... 21**
- 10b. Quick guide: Drainage Mode, probes connected to control..... 23**
- 11. Quick guide: Drainage Mode, float connected to pump 23**
- 12. Quick guide: Pressure Boosting – switched input..... 24**
- 12a. Quick guide: Pressure Boosting – switched input cont..... 25**
- General information re pressure switch set up DUTY/ASSIST..... 25 - 25**
- 13. Quick guide: Transfer – source/destination control..... 27**
- 14. Quick guide: Jacking Pump and Duty Pump 28**
- 15. Quick guide: Transfer – source/destination control..... 29**
- 16. Quick guide: Drainage Mode, 4–20mA level transmitter 30**
- 17. Quick guide: Pressure Boosting 4-20mA 31**
- 18. Quick guide: Transfer – source/destination control 4-20mA 32**
- 19. Backup power supply..... 33**
- 21. Fault Messages 34**
- 22. Accessories..... 35**
- 23. Warranties – Terms and Conditions 36**

	Warning - Electrical safety
	Warning – Potential consequences of use outside of intended application(s). Includes environmental condition warnings.
	Mandatory warning
	Warning to disconnect power
	Read carefully

4. Technical Specifications

Controller Modes	Automatic or Manual pump operation. Liquid level control via float switch, electrode probes OR 4-20mA level transducer. Pressure control via pressure switch or 4-20mA transducer
Protection functions:	Dry run (Underload), Overload, Pump Stalled, Transient surge, Under voltage, Over voltage, Repeated start, Short circuit, Over temperature <i>Over temperature requires an optional relay</i>
Input Voltage	230V +10% -6%
Rated output power	DPC 1-22 nominal 0.37 to 2.2 kW P2 power Max 18A input per pump
Minimum working current	DPC 1-22 = 1 amp per pump
Working temp	-25 to +55 deg C 20% to 90% relative humidity, non-condensing
Enclosure dimensions	350 mm wide, 220mm deep, 450mm tall IP54 Total height including alarm = 500mm
Trip response times (set)	Open phase – Less than 2 sec Short circuit – less than 0.1 sec
Trip Voltage (User adjustable)	Over voltage – Default = 276V Under voltage – Default = 192V
Trip response times (User adjustable)	Dry run (Under-load) 5 sec Under Voltage Less than 5 sec Over voltage Less than 5 sec
Recovery times (User adjustable)	Dry run (Under-load) 45 min default Overload 4 min default Under Voltage 4 min default Over voltage 4 min default
RS485 Technical interface	RS485 Bus Interface: asynchronous semi duplex 1200,2400,4800,9600 bps (default 9600bps) MODBUS protocol (RTU)
Alarms	Visual and audible alarm



To avoid 'nuisance' alarming, many of the default protection parameters have values with a wide tolerance. The installer is encouraged to optimise the settings to achieve optimum results

5. Display

The nXt-DPC display provides a real time indication of the operational mode and the current state of the controller, including real-time voltage/current and any error messages.

Only the icons relevant to the current operational state will display.

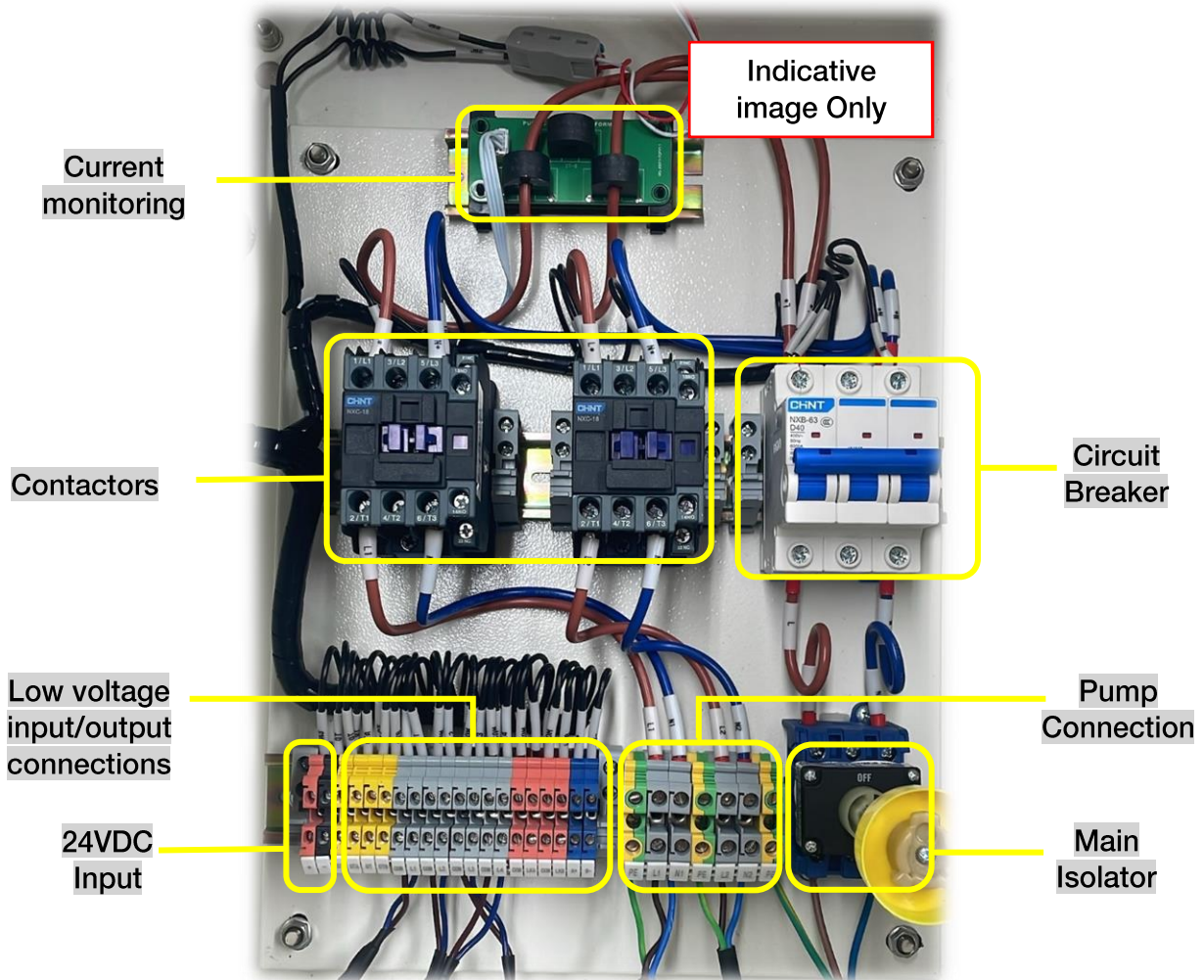
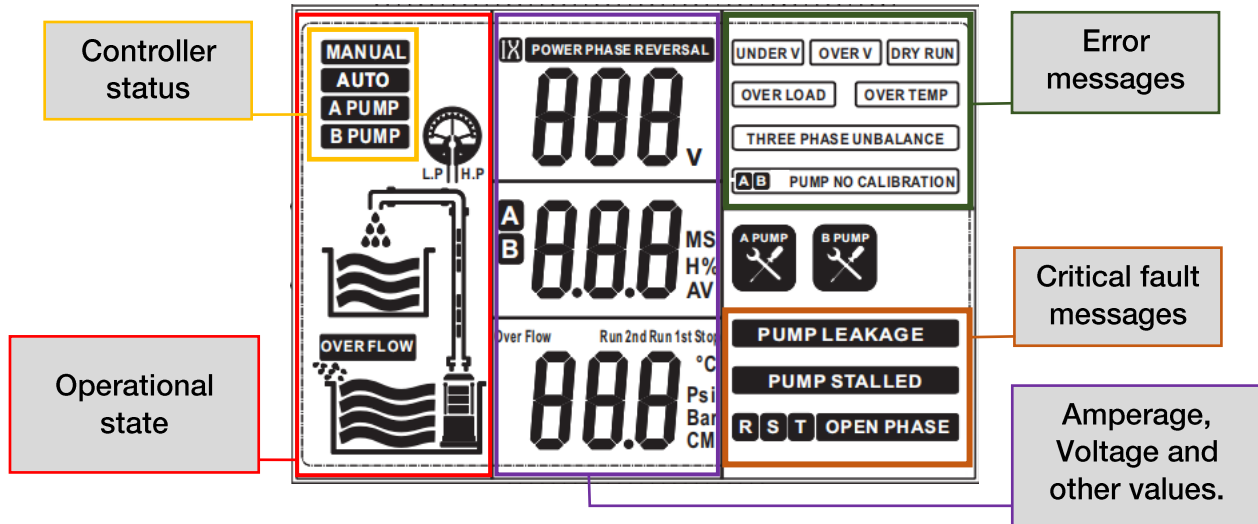

5a. Display con't



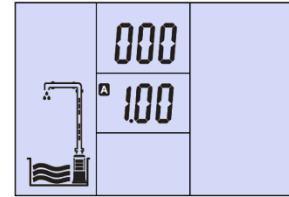

When first powered on the nXt-DPC will briefly display the hardware and the software version.



The nXt-DPC Pro controller operates according to the pre-programmed logic in the control module. Different modes are selected by altering Parameter 003

Examples of common applications are detailed later in this manual but with an understanding of how the controller responds to various inputs the controller can be used for applications other than those applications suggested.

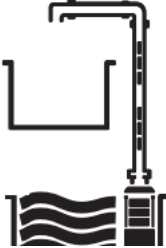
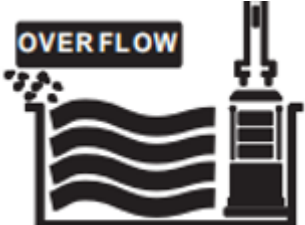
The appearance of the front display changes according to each mode and provides a visual indication to the state of the input signals.

	Lack of source water		High pressure or Low pressure state
	Source water full		Destination low
	Overflow		Destination full

Avoid installing the nXt-DPC Pro where it could experience the following conditions:

- i. Where there is significant vibration and/or mechanical shock.
- ii. Where it could be exposed to corrosive liquids or gasses, or to flammable materials, solvents etc.
- iii. Extreme heat and cold. Operating range -25°C - 55°C.
- iv. Protect the controller from rain, moisture, humidity or dust



Mode 00 - 'Drainage' control by PLC referencing open / closed circuit states

Auto Mode

- I. COM + L1 AND L2 Closed will Start the first pump.
 - a. The pump which runs first will alternate with each successive start signal.
- II. For greater differential connect (float) switches) to COM + L1 AND COM + L2
 - a. COM + L1 Closed the pump is ready to run
 - b. COM + L2 Closed the first pump will Start
 - c. The first pump will not Stop until COM+ L1 Opens
- III. COM + L3 Closed will start the second pump. COM + L3 open will Stop the second pump
 - a. COM + L3 circuit can trigger a pump (ON/OFF) independently of COM L1, L2
- IV. COM + L1, COM + L2 and COM + L3 must ALL be in an Open state to Stop both pumps
 - a. i.e. If COM + L3 is Closed and COM + L1 and COM + L2 are Open, the pump(s) will continue to run until COM + L3 is also Open
- V. COM + L4 closed triggers the Audible/Visual alarm and will start both pumps if they are not already operating. COM+ L4 does not require COM + L1, L2, L3 to be in a Closed state.

Manual mode:

COM + L4 in a closed state triggers Visual/Audible Alarm only

To test the Audible / Visual Alarm, bridge COM + L4

A Start / A Stop and B Start / B Stop operate the pumps manually.

Mode 01 - 'Drainage' control by floats connected to pump

Set Parameter 029 (Dry run delay) to OFF The controller will ignore a zero amp current draw when the pump control switch turns the pump off. Underload protection remains active.

Auto Mode

- I. In this mode. COM + L1, L2 and L3 effectively have no function.
- II. The controller provides power to a pump (Active pump selection alternates)
 - a. The first pump will run until its float switch turns it off and the current draw falls to zero. At this point the controller will switch and supply power to the second pump. When the pump float is in a run state, the 2nd pump will operate.
- III. COM + L4 in a Closed state triggers the Audible and Visual Alarm AND supplies power to both pumps. Both pumps and the alarm will operate until COM + L4 returns to an Open state (at which point the alarm ceases) Both pumps continue to run until their individual floats Stop the pumps running

Note: For the controller to switch to the second pump, the PLC must first register current draw greater than zero, and then a return to zero. In the event of a pump failure, the second pump may not operate until triggered by the COM+ L4 circuit closing.

Mode 02 - 'Boosting' control by PLC referencing open / closed circuit states

Auto Mode

- I. COM + L1 AND L2 (Closed) control whether the pump(s) will run. [Bridge L1 to L2](#)
This circuit over-rides everything else
Typically, this is used as the low water level circuit. Open circuit = No-run state
- II. COM + L3 Closed will Start a pump. COM + L3 Open will Stop that pump
 - a. COM + L3 circuit can trigger a pump (ON/OFF) independently of COM L4
- III. COM + L4 Closed will Start a pump. COM + L4 Open will Stop that pump
 - a. COM + L4 circuit can trigger a pump (ON/OFF) independently of COM L3
- IV. Once both pumps are running (triggered by COM + L3 AND COM + L4) both will continue to run until COM + L3 AND COM + L4 return to an Open circuit
COM + L1 Open circuit will Stop both pumps (even if COM+L2 is still Closed)

In the event that COM+ L3 AND COM + L4 close simultaneously, to minimise in-rush current load, the first pump will start and after a 7 second delay the second pump will start.

Additional parameters are available in Boosting mode

Parameter 005: Repeated Start Protection (default Off) can be programmed to set the maximum allowable start signals in a one-minute period. If the value is exceeded (i.e. pressure switch bouncing), the Visual / Audible alarm activates. This is considered a CRITICAL ALARM. Cycle the controller power supply to clear.

Parameter 015: Maximum Run Time (default Off) can be programmed to set a maximum run time of up to 254 minutes.

If a single pump is running and the control circuit is still in a run state, the second pump will start. After the set time, operation will revert back to the other pump etc.

If both pumps are running, when the maximum run time is exceeded, both pumps will stop and the Visual / Audible alarm activates.

If **Parameter 016: Fault Alarm Recovery** (default Off) setting is OFF, it will be necessary to cycle the controller power supply to clear the Alarm

If Parameter 016 is set to 01 hr or greater, the alarm will clear automatically after the setting time has elapsed

A suitably sized pressure tank MUST be installed to manage pump start frequency

Mode 03 - 'Transfer' control by PLC referencing open / closed circuit states

DUTY / ASSIST – 2 x Pumps of equivalent performance.

Auto Mode

- I. COM + L1 (Closed) controls whether the pump(s) will run or not
This circuit over-rides everything else
Typically, this is used as the low water level circuit. Open circuit = No-run state
The Duty Pump alternates each successive pump Start
- II. [Bridge L4 to L3](#) if the intention is to use a single control switch
- III. IF COM + L3 is Open, COM + L4 controls starting of the first pump.
 - a. COM + L4 - Open to start
 - b. COM + L4 – Closed to Stop a pump.
- IV. When COM + L2 Opens the second pump will Start
- V. Both pumps will run until COM L4 Closes (even if COM L2 and L3 are Open)
- VI. Opening L4 and L2 circuits will not achieve anything until the L3 circuit Opens to Start the first pump.

In the event that both pump control circuits operate simultaneously, to minimise in-rush current load, the first pump will start and after a 7 second delay the second pump will start.

Mode 04 - 'Transfer' control by PLC referencing open / closed circuit states

DUTY / STANDBY – 2 x Pumps of equivalent performance.

Maximum of 1 pump running at a time

[Bridge L1 to L2](#) (COM+L2 functions only to alter display appearance) [Bridge L3 to L4](#)

Auto Mode

- I. COM + L1 + L2 (closed) controls whether the pump(s) will run or not
This circuit over-rides everything else
Typically, this is used as the low water level circuit. **Open circuit = No-run state**
The Duty Pump alternates each successive pump start
- II. COM + L3 + L4 Open to start (L3 must be open for L4 to function)
- III. COM + L3 + L4 Closed to stop (L4 controls the Stop function irrespective of L3 state)

Changing Parameter 03 to Modes 05 – 07 opens an additional 5 parameters which makes control setup simple.

033	200 cm / 2 bar	Transducer measurement range
034	100 cm / 10 bar	Stop setting Level or pressure
035	40 cm / 4 bar	Start setting Level or pressure
036	20 cm / 2 bar	Second pump start setting Level or pressure
037	150 cm / 20 bar	Alarm setting Level or pressure

Mode 05 - 'Drainage' control by PLC referencing 4-20mA sensor

COM + L2 is a backup High Level Alarm Circuit.

Should the 4-20mA sensor fail to operate, the COM + L2 circuit in a Closed state triggers the Audible / Visual alarm and starts both pumps if they are not already running.

Level control setting values refer to the source liquid level

Mode 06 - 'Boosting' control by PLC referencing 4-20mA sensor

Bridge L1 to L2 COM + L1 + L2 controls whether the pump(s) will run or not. Closed = no-run
Typically run / no-run protection is installed at the source.

Setting values are pressure in the delivery line.

A suitably sized pressure tank MUST be installed to manage pump start frequency

Mode 07 - 'Transfer' control by PLC referencing 4-20mA sensor

Bridge L1 to L2 if employing a single control (float) switch at the source

COM + L1 + L2 controls whether the pump(s) will run or not. Closed = no-run

Level control setting values refer to the destination liquid level

Pressure switch types

The most common type of pressure switch used for pump control is of Normally Closed configuration. When the pressure rises to the set-point, the switch opens the control circuit.

Normally Open variants are available. These provide a Closed circuit at the upper pressure setpoint and an open circuit at low pressure

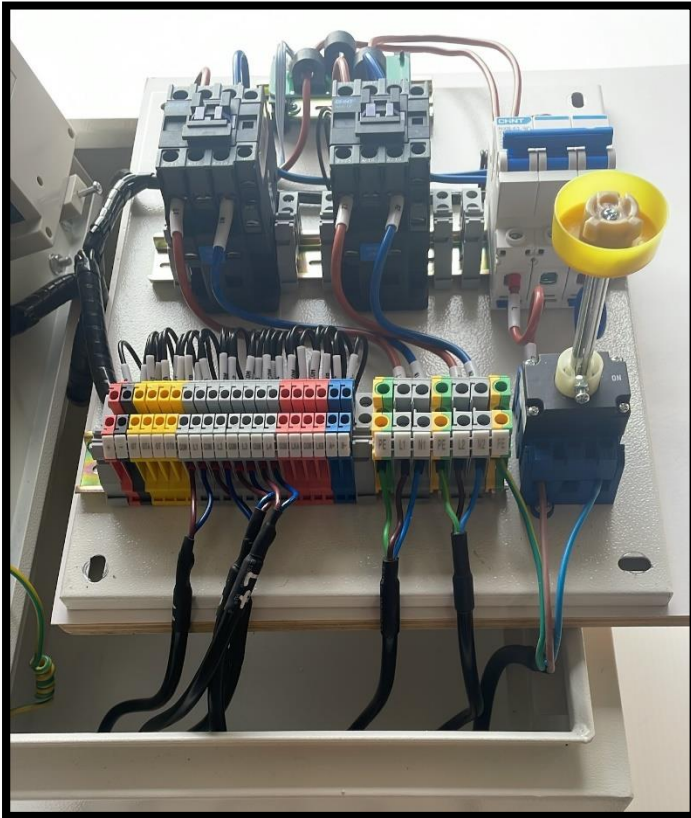

The internal sub board may be lifted free of the outer casing by removing the four M6 (10mm A/F) nuts and snipping the two plastic cable ties

An additional 220mm of cable length is necessary

Total length (past cable gland) approx. 350mm

Ensure the power supply wiring is rated for the current draw of BOTH pumps



It is the responsibility of the installing electrical technician to ensure that the cable cross section (mm²) meets the requirements of AS/NZS 3008; taking into consideration the cable type, the cable length, the current draw and other relevant factors.

If in doubt, online resources exist i.e. Cable Size Calculator AS/NZS 3008 or seek advice from an electrical engineer or other suitably qualified person(s)

Pump over temperature protection sensor wiring terminal

Terminal	Definition
#1: OT and OTA	Pump over-temp protection sensor. Standard thermals will open to peak signal and stop pump on overheat PT100 connection. The circuit looks for the variable signal from a PT100 sub-board
#2: OT and OTB	

Pump moisture protection sensor wiring terminal

Terminal	Definition
COM and LKA COM and LKB	Pump leakage protection (moisture) sensor

4-20mA transmitter wiring

Terminal	Definition
L3 (P+) and L4 (P-)	4-20mA level/pressure transmitter

RS485 communication terminal

Terminal	Definition
A+ and B-	RS 485

Full factory reset

- Turn off power to the control panel,
- Press and hold the **A-STOP** button and reapply power
- When the display shows 099, release the **A-STOP** button.
-

Note that Parameter #003 will remain as previously set.
All other parameters reset to factory defaults

7. Modbus

Main technical data	
Physical interface	RS485 Bus Interface: asynchronous semi duplex
Data format	1 start bit, 8 data bit, 1 stop bit, no verify 1 start bit, 8 data bit, 2 stop bit, no verify Default: 1 start bit, 8 data bit, 1 stop bit, no verify
Baud rate	1200,2400,4800,9600 bps (default 9600bps)
Communication address	Setting range of controller address: 1-126. 127: broadcast address, host computer broadcasting, slave machine response forbidden
Protocol type	MODBUS protocol (RTU)
Rated input voltage for SC	AC 240V/50Hz, single phase
Main installation data	
Wire communication distance	1200 m max by shield twisted pair cable (STP)for RS485 & CAN 5000 m max by STP and RS485 extender
STP	STP-120U one pair 20AWG for RS485 & CAN

8. Parameter Calibration



The pump must be able to pump water to enable correct calibration. Calibrated without water, overload and pump stalled errors may occur later. Calibration can be performed automatically as explained on Page 3 OR by accessing the User parameter menu and manually inputting the desired value(s)

When a new pump is installed, or an existing pump reinstalled after maintenance, erase the former calibration and a perform a fresh calibration.

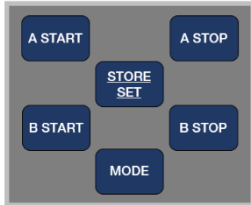

To access parameter settings the controller should be in **Manual Mode** and the pump should NOT be running.

Press the **STORE/SET** button for **5 seconds** to enter at Parameter 021

Press the **STORE/SET** button then the **MODE** button for **5 seconds** to enter at Parameter 03

To enter a parameter, press the **STORE/SET** button to advance to the next parameter and display the current value.

To increase a value, press **A-START** To decrease a value press **A-STOP**

Short press of the **STORE/SET** button to store a value.

Short press of the **MODE** button to save all changes and exit

9. Program Parameters

Controller unlocked

Press  to switch between AUTO and MANUAL mode

Controller locked (Parameter 017 active)

Press and hold  for 5 sec to switch to MANUAL mode

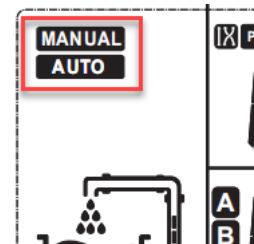



The controller operating mode will be displayed in the top left corner of the display

9a. Program Parameters cont

ITEM	DEFAULT	OPERATION
003	00	<p>Controller Operation Logic</p> <p>00 = 'Drainage' Mode where the control inputs (generally level floats or probes) are located at the source. (default)</p> <p>01 = 'Drainage' Mode where the level control input is managed by a flexible float on the pump.</p> <p>02 'Pressure Boosting' Mode. Main control via (N/C) pressure switch. Supports run / no run level protection at the source via floats or probes.</p> <p>03 = 'Transfer' Mode. DUTY / ASSIST Main control via control inputs (floats or probes) at destination or by a pressure switch on the delivery line. Supports run / no run level protection at the source.</p> <p>04 = 'Transfer' Mode. DUTY / STANDBY Main control via control inputs (floats or probes) at destination or by a pressure switch on the delivery line. Supports run / no run level protection at the source.</p> <p>05 = 'Drainage' Mode with overflow alarm through a 4-20mA level transmitter. Program levels (cm)</p> <p>06 = 'Pressure Boosting' Mode controlled via a 4-20mA pressure transmitter. Supports run / no run level protection at the source via floats or probes. Program pressures (bar)</p> <p>07 = 'Transfer Mode' with 4-20mA level transmitter at the destination. Supports run / no run level protection at the sources via floats or probes. Program levels (cm)</p>
004	05 sec	<p>Pump Stall Delay Time (ignore time for in-rush current) Range: 0 – 60 sec</p>
005	Off	<p>Boosting mode only - Repeated start protection Values greater than 0 represent maximum starts in a 1 minute period before repeat start protection activates Range: 0 – 50</p>
006	Off	<p>Over temp Protection Options: On / Off</p>
007	SET TO OFF	<p>Phase Reversal Protection N/A DPC 1-22 Model When using the nXt DPC in conjunction with a VFD set to OFF</p>
008	SET TO OFF	<p>Open Phase Protection N/A DPC 1-22 Model When using the nXt DPC in conjunction with a VFD set to OFF</p>

9b. Program Parameters cont

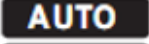
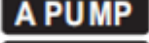
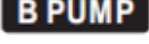
009	On	<p>Pump enable / disable function</p> <ul style="list-style-type: none"> • B pump enabled, A Pump Disabled • Both pumps A pump and B pump enabled • A pump enabled, B Pump Disabled <p>An indicator on the left hand side of the screen shows which pump(s) are enabled. Disabled pump(s) are indicated by  icon(s) on the RHS</p>
010	On	<p>Auto and Manual function setting</p> <ul style="list-style-type: none"> • Both Pumps automatic operation • A Pump Automatic operation, B Pump Manual operation • B Pump Automatic operation, A Pump Manual operation <p> After exiting the programming menu and returning to Automatic operation, a flashing manual icon in the upper left indicates that one of the pumps is set to permanent manual operation.</p> <p>   Whenever a pump is running, its icon will flash</p>
011	Off	<p>Pump Alternation: The continuous running time after which the operating pump will alternate. Not related to start alternation</p> <p>Range Off – 254 min</p>
012	96 hrs	<p>Anti-seize setting</p> <p>Range: 00 – 254 hrs</p>
013	Off	<p>Start delay time</p> <p>Suggest setting to minimum 1 sec</p> <p>Range Off – 254 sec</p>
014	Off	<p>Stop delay time</p> <p>Range Off – 254 sec</p>
015	Off	<p>Boosting mode only – maximum run time</p> <p>Range Off – 254 min</p>
016	Off	<p>Fault Alarm audio setting</p> <p>When a fault occurs and activates the alarm, after the time specified in parameter #013 & #016 the continuous alarm will switch to chirp mode (lasts 1sec) at 5-minute intervals.</p> <p>Range: 00 – 254 hrs</p>
017	Off	<p>Button Lock Function</p> <p>Options 0 = Off, 1 = On</p>
018	01	<p>RS485 - Controller ID</p> <p>Range 00 – 254</p>
019	04	<p>RS485 – Baud Rate</p> <p>01 = 1200, 02 = 2400, 03 = 4800, 04 = 9600 bps (default 9600bps)</p>
020	00	<p>RS485 Parity Check</p> <p>00 = None, 01 = Odd Parity, 02 = Even Parity</p>
021	25.0A	<p>Rated Output i.e. Pump Calibration Value – A Pump</p> <p>Range: 0 – 25 Amps</p>
022	25.0A	<p>Rated Output i.e. Pump Calibration Value – A Pump</p> <p>Range: 0 – 25 Amps</p>
<p>Whenever a replacement pump(s) is installed, the previous calibration(s) should be removed and new calibration values entered</p>		

9c. Program Parameters cont

023	75%	Trip response ratio – Under-load protection Range: Off – 95%
024	130%	Trip response ratio – Over-load protection Range: Off – 170%
025	180%	Trip response ratio – Pump stalled / locked rotor protection Range: Off – 195%
026	SET TO OFF	Trip response ratio – Phase imbalance N/A DPC 1-22 Model
027	192V	Trip voltage – Under Voltage Protection Range 00 – 312 V
028	276V	Trip voltage – Over Voltage Protection Range 00 – 312 V
029	05 sec	Trip response time – Dry run Protection delay time Range 1 – 553 sec
030	45 min	Recovery time – Dry run Protection restart delay time Range 1 – 60 min
031	04 min	Recovery time – Overload protection restart delay time Range 1 – 254 min
032	04 min	Recovery time – Under/Over Voltage restart delay time Range 00 – 60 min

When Parameter #3 is setting to logic mode 05, 06, or 07

033	200 cm / 2 bar	Transducer measurement range
034	100 cm / 10 bar	Stop setting Level or pressure
035	40 cm / 4 bar	Start setting Level or pressure
036	20 cm / 2 bar	Second pump start setting Level or pressure
037	150 cm / 20 bar	Alarm setting Level or pressure



nXt-DPC Pro controllers offer a cost-effective and dependable solution for enhancing control and protection, eliminating the need for expensive customized switchboards.

On the following pages you'll find concise guides outlining typical applications. Once you grasp how the controller reacts to inputs across its modes, you'll discover its potential for applications beyond the standard suggestions.

For instance, you can integrate the controller in line with a VFD pump controller to introduce additional control inputs or capitalize on the nXt-DPC controller's delay capabilities.

For heightened flexibility in your setup, consider employing the nXt-DPC controller as a modular component within a more intricate control system.



Source control - Single float

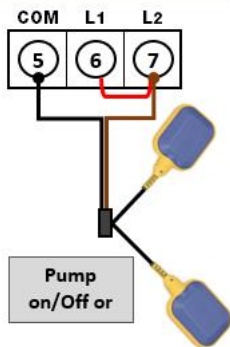

Floats

3 wire' floats allow for NO or NC wiring.

Connecting to the controller using the black and brown wires the circuit is closed when the float is up, open circuit when the float is down

When using a single float on the source input terminals, L1 and L2 must be bridged

Source control - dual float

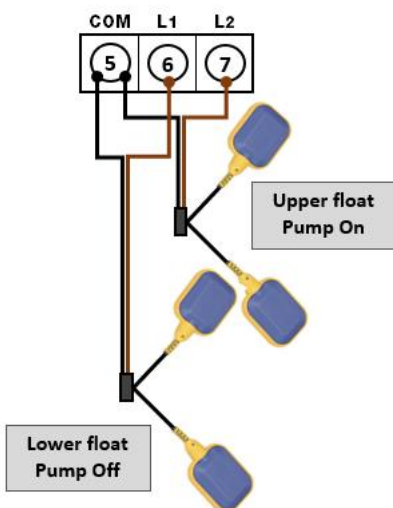

When the logic mode supports it, to achieve greater differential, dual floats may be attached to the source inputs COM + L1 and COM + L2.

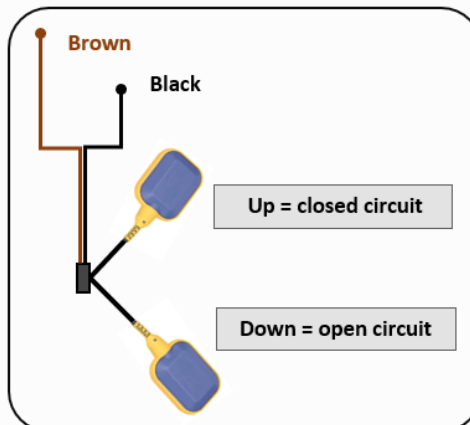

10. Quick guide: Drainage Mode, floats connected to control

Parameter 003 = **00** Default mode as supplied

A pump with its own float can be used in this configuration so long as the operational level of **Pump Stop Switch L1** is HIGHER than the float attached the pump.

3 Float Operation (High Level Alarm requires 1 additional float)

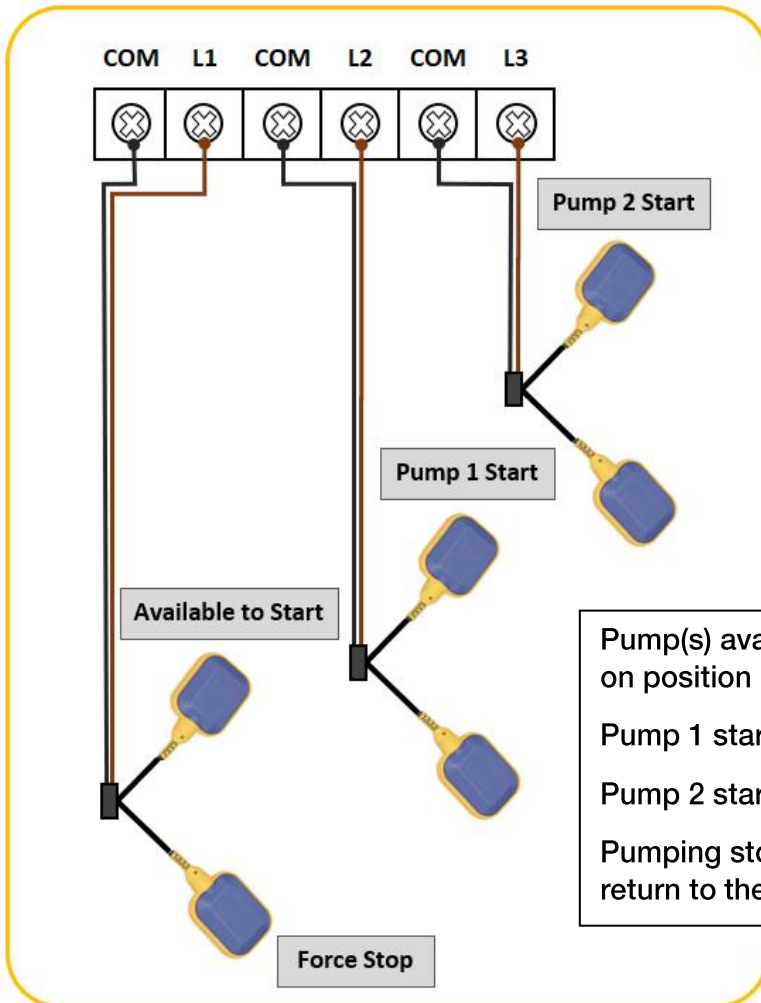

Pump(s) available to start when L1 is in the on position
 Pump 1 starts when L2 is in the on position
 Pump 2 starts when L3 is in the on position
 Pumping stops when L1, L2 and L3 all return to their off level.

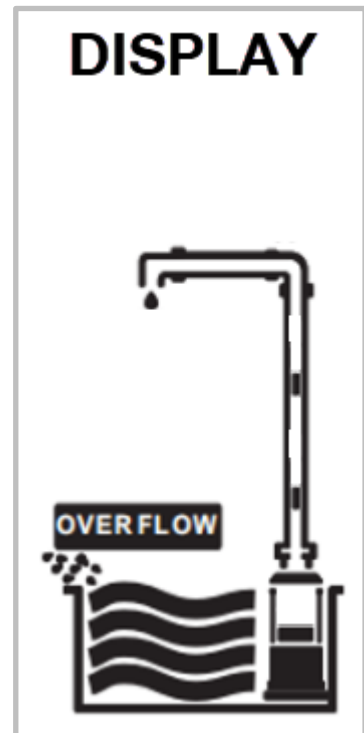

(Optional) High Level Alarm

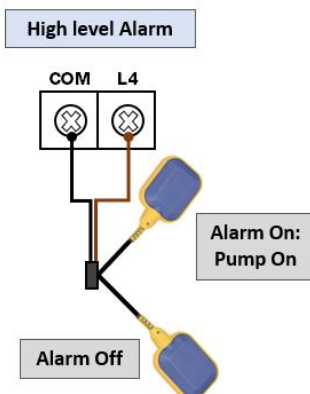

High-Level alarm triggers when the High-Level alarm float switch COM + L4 is in the On (Up) position. This will trigger all pumps to run

The alarm will turn off when the Hi Level alarm switch connected to COM + L4 returns to the Off (Down) position.

The pump(s) will continue to run until all control circuits (L1, L2, L3 and L4) are in their Down, Off, position

10a. Quick guide: Drainage Mode, floats connected to control

Parameter 003 = **00** **Default mode as supplied**

A pump with its own float can be used in this configuration so long as the operational level of **Pump Stop Switch L1** is **HIGHER** than the float attached the pump.

2 Float Operation (High Level Alarm requires 1 additional float)

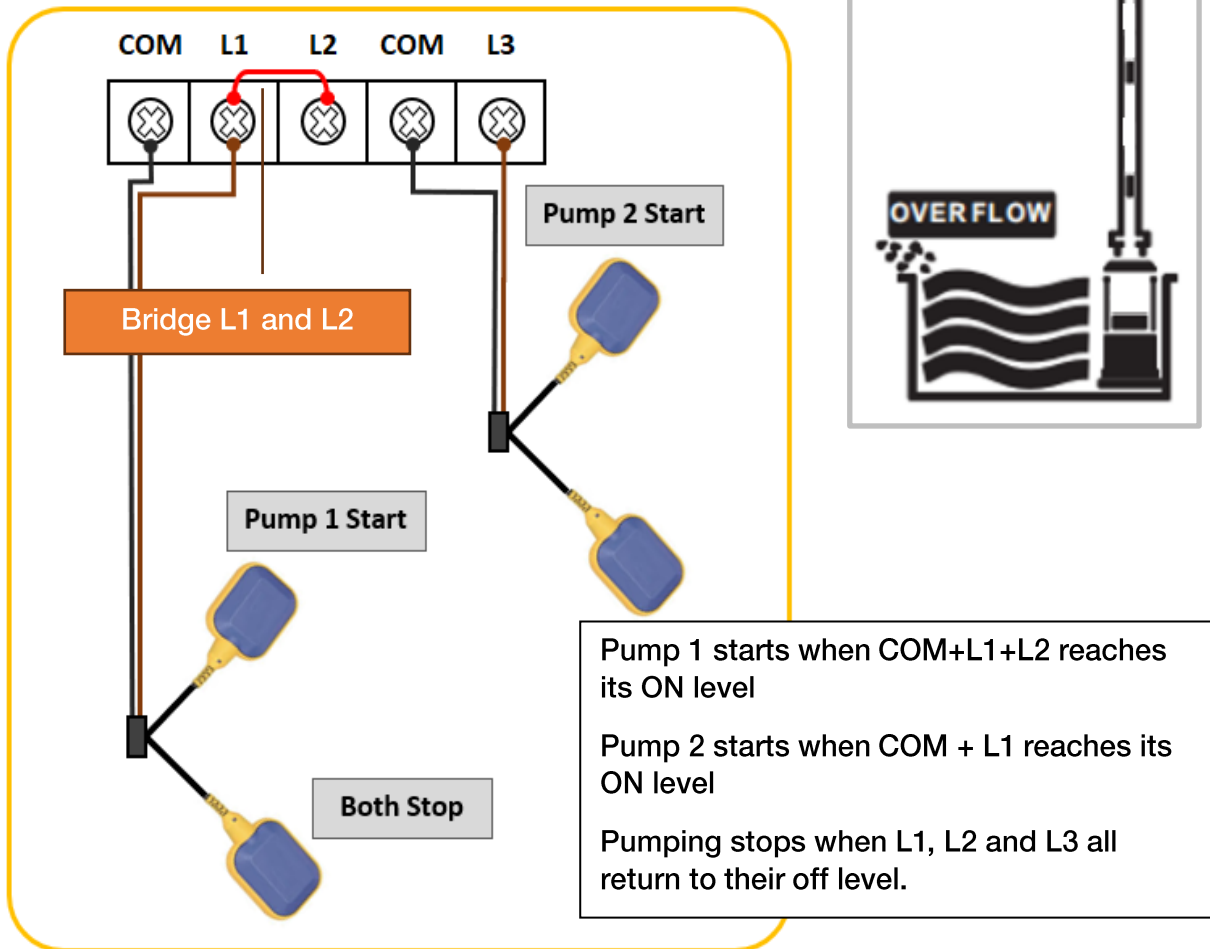

(Optional) High Level Alarm

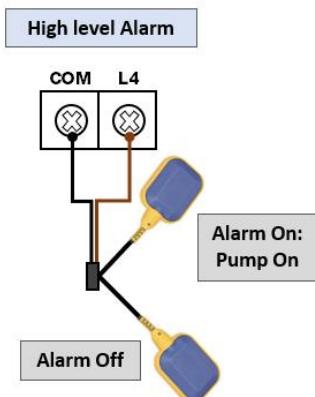

High-Level alarm triggers when the High-Level alarm float switch COM + L4 is in the On (Up) position. This will trigger all pumps to run

The alarm will turn off when the Hi Level alarm switch connected to COM + L4 returns to the Off (Down) position.

The pump(s) will continue to run until all control circuits (L1, L2, L3 and L4) are in their Down, Off, position

10b. Quick guide: Drainage Mode, probes connected to control

Parameter 003 = **00**

The use of probes in heavily contaminated wastewaters is not recommended

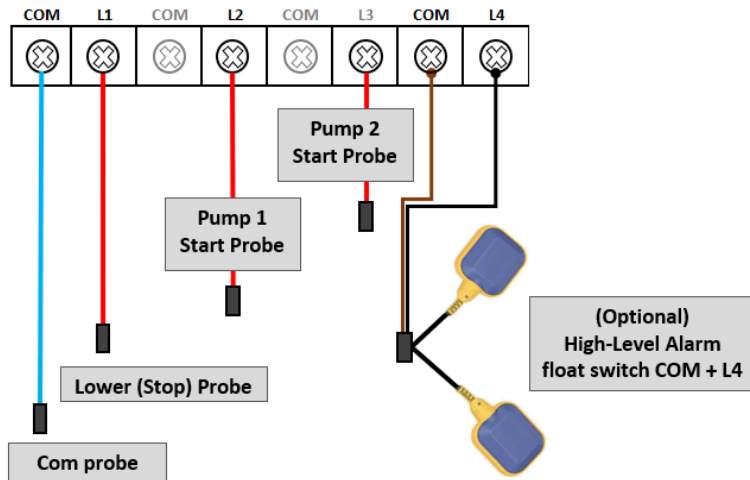

11. Quick guide: Drainage Mode, float connected to pump

Parameter 003 = **01**

Set to this operational mode, effectively there is power supplied to one or the other pump continuously. The stop/start function is controlled by the float connected to each individual pump.

Set Parameter #029 (Dry Run delay) to OFF

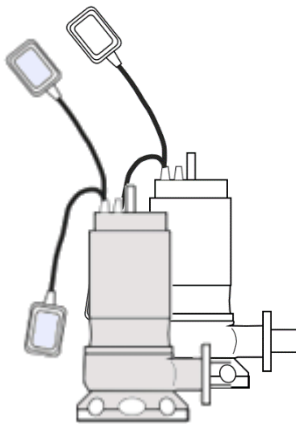

The pump On/Off operation is controlled by the float fitted to the pump.

Each time the running pump stops, the controller will switch to the other pump awaiting its control float to reach its upward ON position

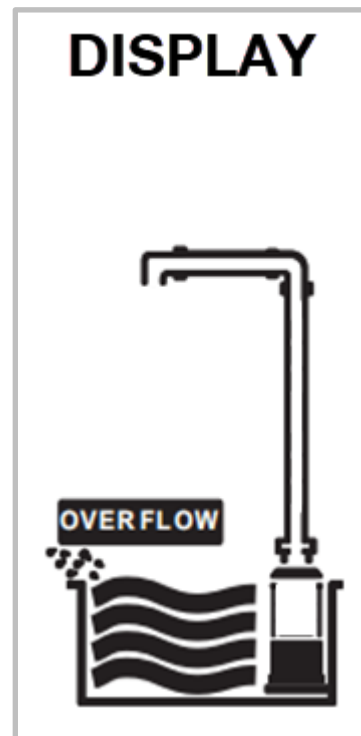

Optional High Level Alarm

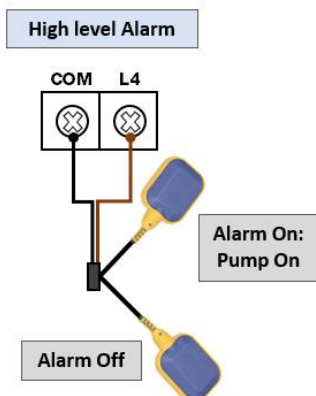

The High-Level alarm triggers when the High-Level alarm float switch COM + L4 is in the On (Up) position.

The alarm will turn off when the Hi Level alarm switch connected to COM + L4 returns to the Off (Down) position.

The pump continues to run until COM + L4 is in the Off (Down) position AND both pump control floats are in a downward, Off position

12. Quick guide: Pressure Boosting – switched input

Parameter 003 = **02**

Pump On/Off operation is controlled via a pressure switch on the delivery line.

Additional (optional) run/no run protection can be fitted at the source

Pumps used for pressure boosting controlled by a pressure switch MUST include a suitably sized pressure vessel to prevent excessive pump starts

**Pressure Tank pre-charge recommendation:
66% of the cut out pressure.**

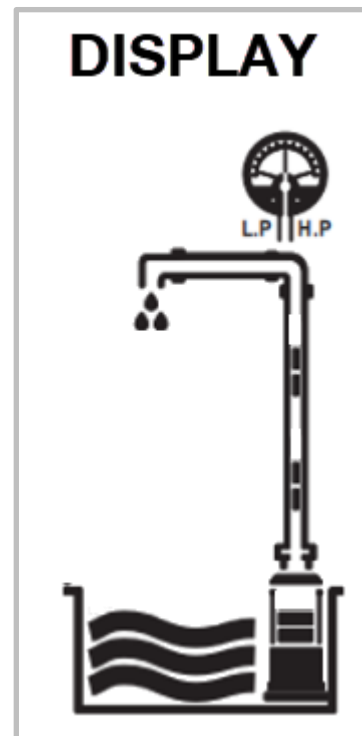

Bridge L1 and L2

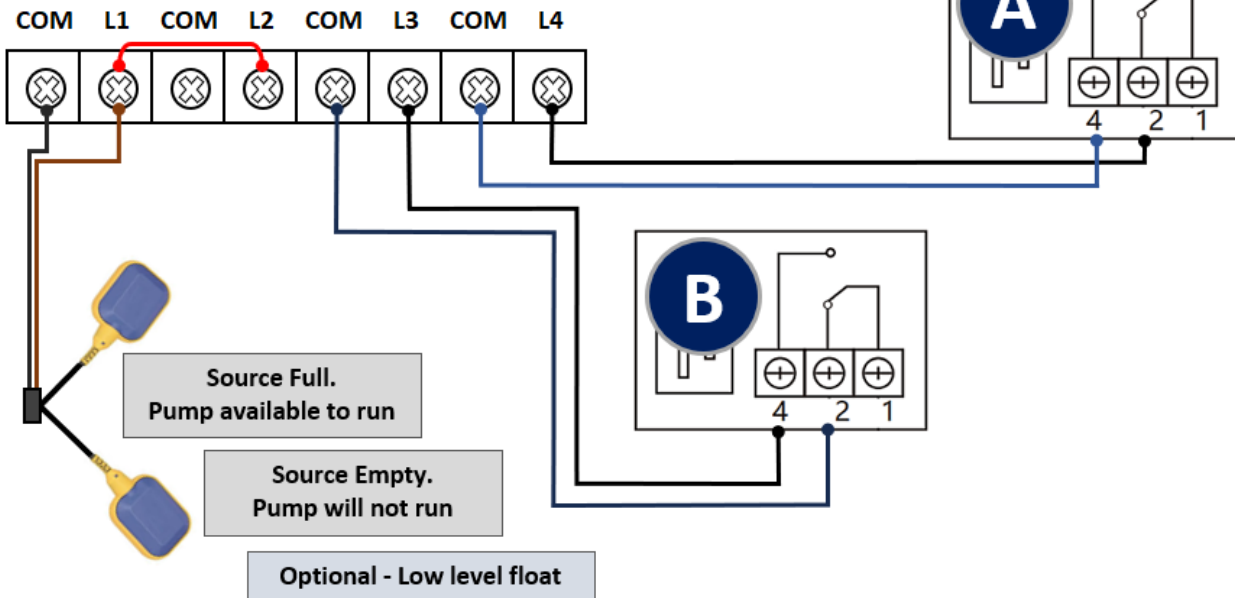

When the controller is set to Boosting Mode, Parameters 013 – 015 can be employed to provide additional control.

- Start delay time **Parameter 013** – Default Off. **Set to min 1 sec**
- Stop delay time: **Parameter 014** – Default Off. **Set to min 1 sec**
- Maximum Run time: **Parameter 015** – Default Off

Parameter 015 provides repeated start protection when in boosting mode

12a. Quick guide: Pressure Boosting – switched input cont

Run / No run control can be achieved using floats or probes.

This will prevent the pump(s) starting if insufficient water is available

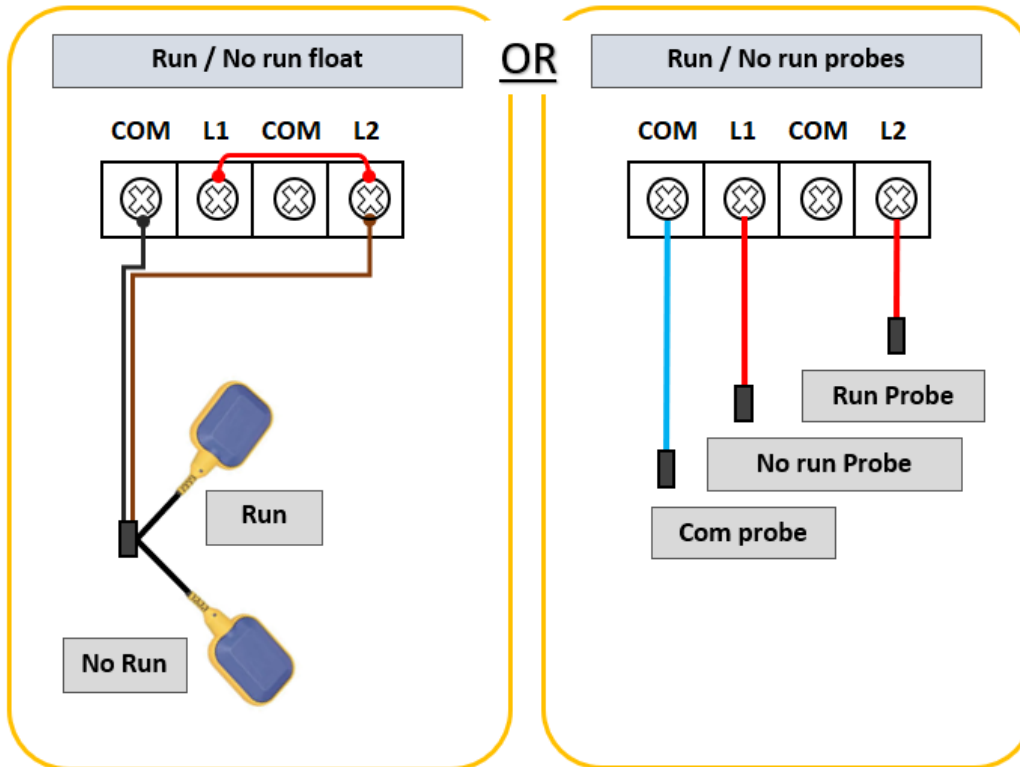

General information re pressure switch set up DUTY/ASSIST

Parameter #009 and #010 selected reflect the number of pumps connected, active and in automatic operation.

Ensure the maximum Cut Out pressure is set 0.3 – 0.5 bar less than the pump maximum pressure to ensure the pump will turn off reliably.



While it is possible to use pumps of similar or equivalent performance, best results will be achieved with identical pumps. The PLC automatic alternates the start pump each pumping cycle

Having the pump hydraulic performance curve to consult will allow the installer to make informed setup decisions

General information re pressure switch set up cont

Selecting the Cut in and Cut out pressures for 2 identical pumps:

1. Pump A (Duty Pump) Set the Cut-Out pressure. Ensure it doesn't exceed the pump maximum head.
2. Pump B (Assist pump) Set the Cut-In Pressure toward the lower end of the Duty Pump performance.
3. Set the Pump A (Duty Pump) Cut-In and the Pump B (Assist Pump) Cut-Out halfway between the maximum and minimum settings.
4. Note that when both pumps are running, they will continue to do so until the Duty Pump Cut-Out pressure is achieved.

EXAMPLE

In this example Pump A (Duty Pump) will start when the system pressure drops below 4.0 bar.

If Pump A (Duty Pump) cannot keep up with the demand flow and pressure drops to below 2.5 bar, Pump B (Assist Pump) will start.

As demand flow reduces, the system pressure will increase. Both pumps will continue to run until the Maximum

When demand flow further decreases Pump A will turn off when system pressure reaches 5.5 bar.

- The default setting) has the pumps alternating each time the system starts
- Setting pump exchange time can be used to initiate a swap between pump A and B after an elapsed time to prevent excessive operation of a single pump.
- A suitably sized pressure vessel should be incorporated in the system to ensure pump starts don't exceed 30 starts/hour OR the manufacturers recommendation.

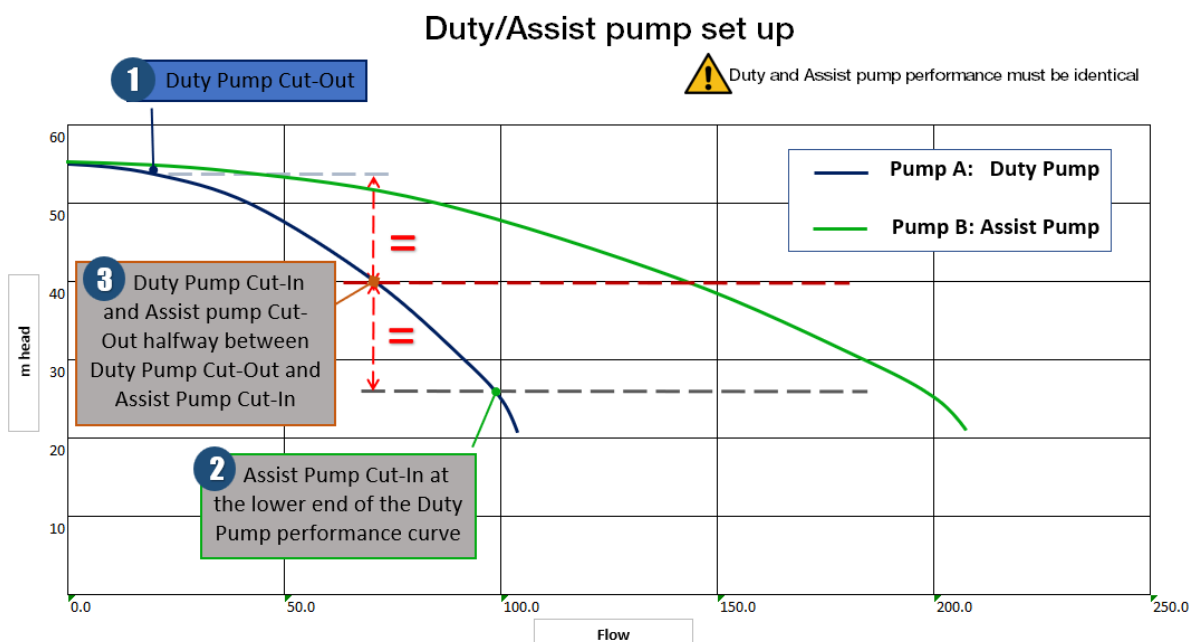

13. Quick guide: Transfer – source/destination control

Parameter 003 = **03** DUTY / ASSIST

Pump On/Off operation is requested by a float at destination in the down (low level = ON) position (or a pressure switch in the delivery line dropping to cut-in pressure and opening)

A float switch at the source controls whether the pump will run or not, depending on the liquid level.

A mixture of floats and probes can be used

In situations where the destination is a significant distance from the source it is possible to control by fitting a normally-open pressure switch to the delivery line OR to use a remote wireless sensor to trigger a switched input.

Connect across COM and L3, Bridge L3 to L4

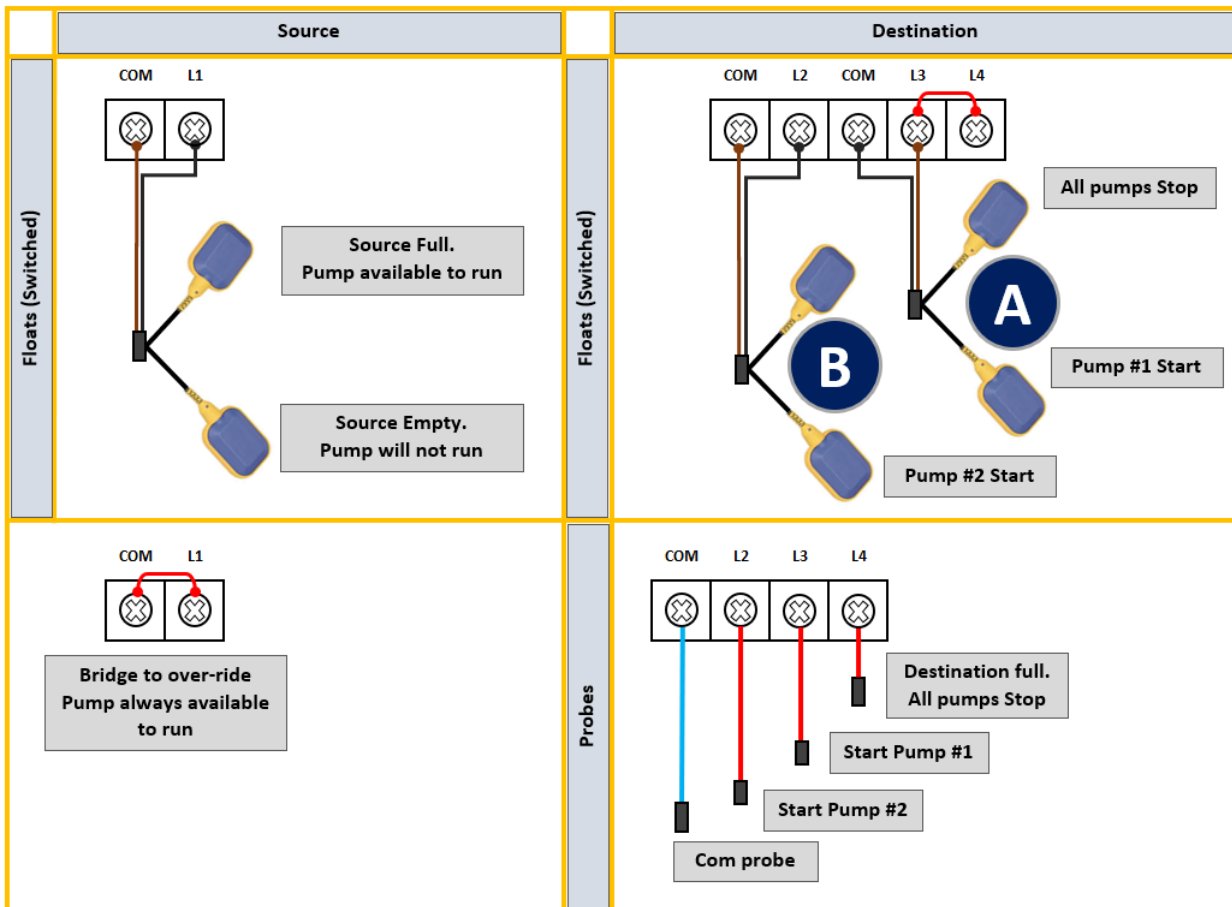
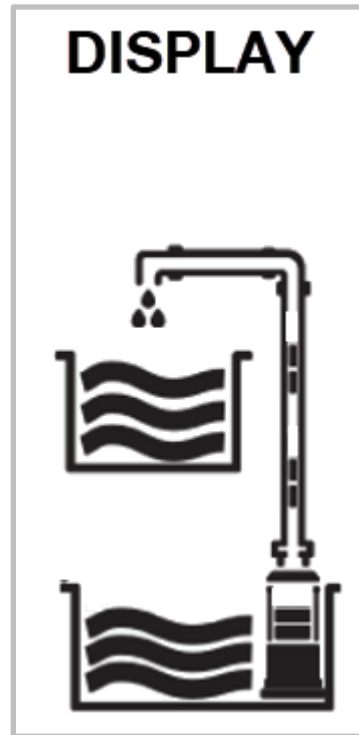

14. Quick guide: Jacking Pump and Duty Pump

Parameter 003 = **03 JACKING / DUTY**

Some situations require a small jacking pump to supply a continuous small water demand, but the main duty flow is substantial in comparison. In these situations, it isn't practical to use 2 pumps of equivalent performance.

To employ pumps of dissimilar performance:

- Set Parameter #010: A Pump Manual / B Pump Automatic
- Set Parameter #029: Dry Run protection trip response to OFF

The jacking pump must be fitted with its own pressure switch OR a digital pressure controller such as the nXt Pro dual mode, flow through controller.

Connect a switched input to COM+L3+L4. The Duty Pump starts when this circuit opens.

Connect the smaller Jacking Pump to L1, N1
Parameter #021: Set the Jacking Pump calibration.

Connect the Duty Pump to L2, N2
Parameter #022: Set the duty pump calibration.

Select **Auto Mode** then press and hold A-START to start the Jacking Pump manually.

The Jacking Pump will operate according to its own controller but benefits from the protection afforded by the DPC-1 Pro Panel (over/under load, under/over voltage etc)

EXAMPLE

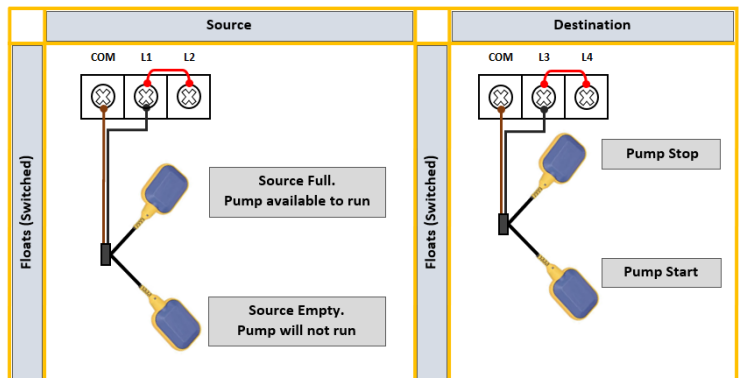

Jacking/Duty pump set up

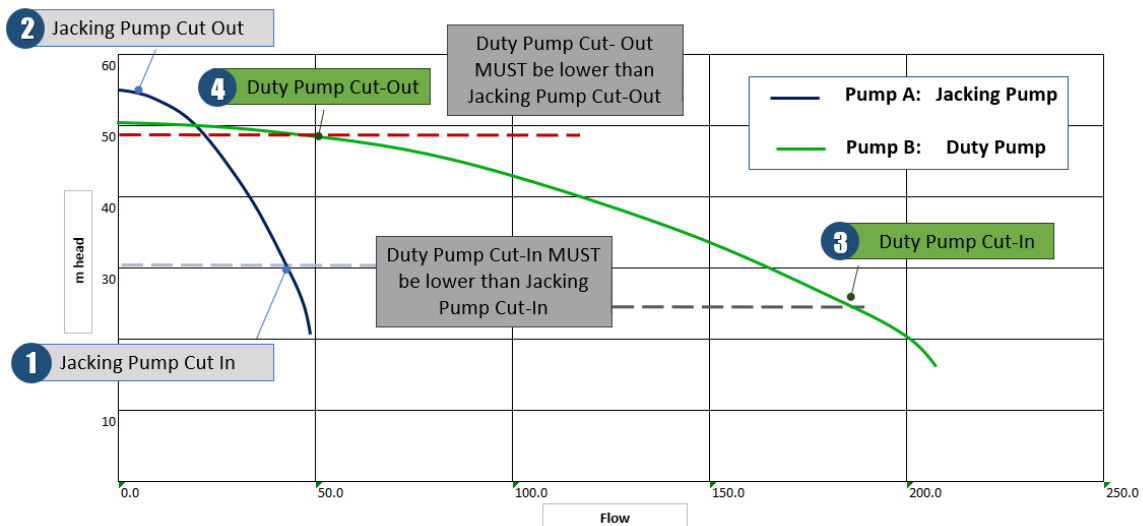

15. Quick guide: Transfer – source/destination control

Parameter 003 = **04 DUTY / STANDBY**

Pump On/Off operation is requested by a float in the down (low level = ON) position at destination (or a pressure switch in the delivery line dropping to cut-in pressure)

A float switch or probes at the source controls whether the pump will run or not, depending on the liquid level.

A mixture of floats and probes can be used

In situations where the destination is a significant distance from the source it is possible to control by fitting a normally-open pressure switch to the delivery line OR to use a remote wireless sensor to trigger a switched input.

Connect across COM and L3, Bridge L3 to L4

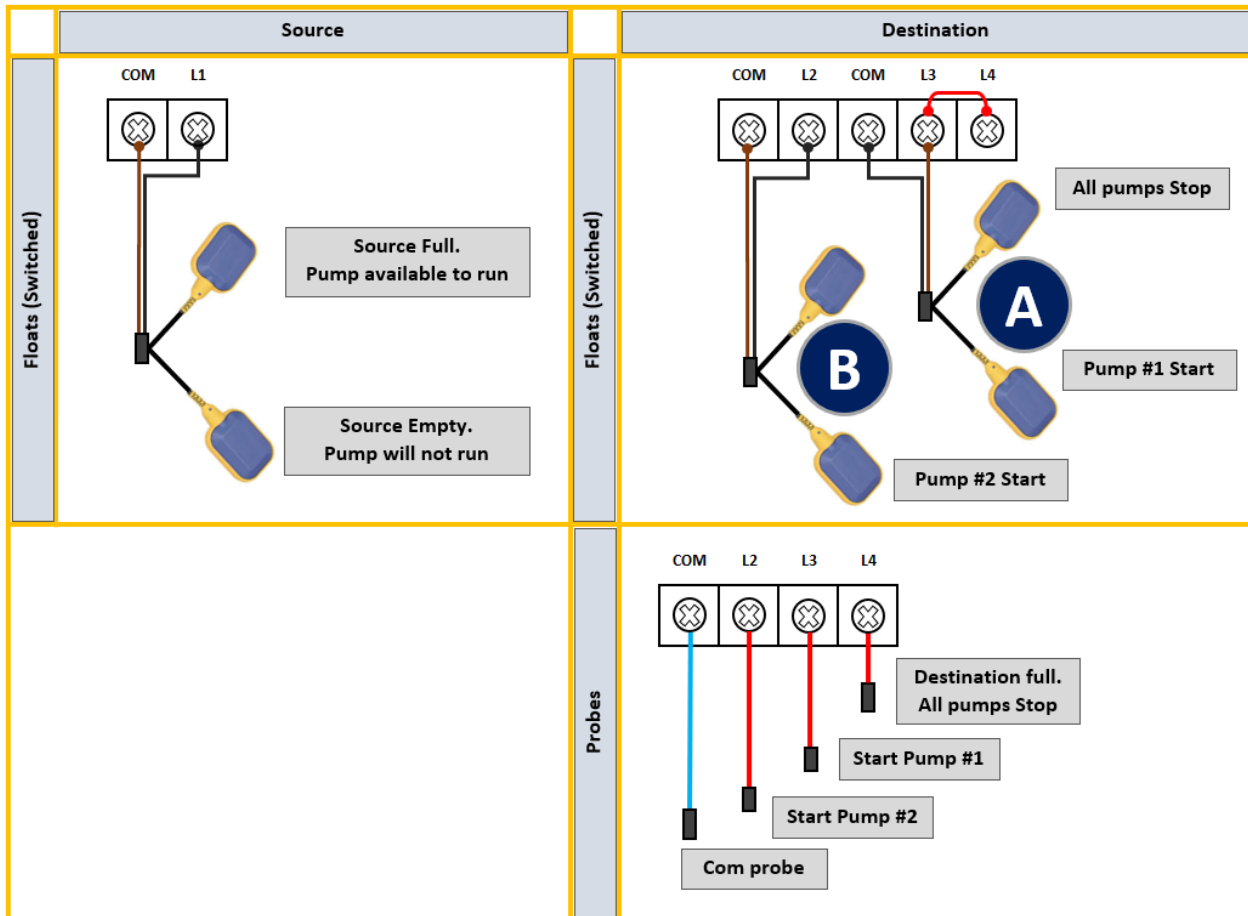
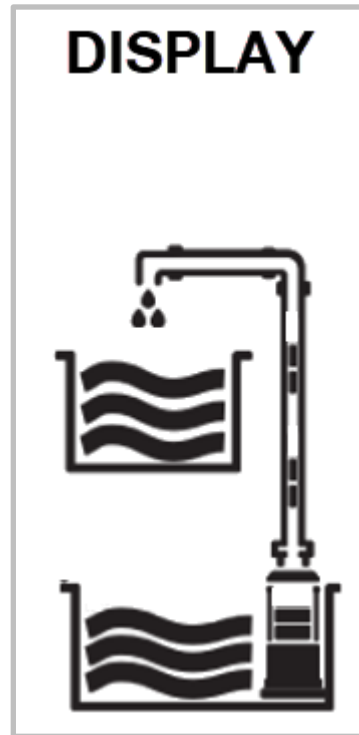

16. Quick guide: Drainage Mode, 4–20mA level transmitter

Parameter 003 = **05** **4-20mA input.**

A pump with its own float can be used in this configuration so long as the Parameter 030 is HIGHER than the level at which the pump float switches the pump off



Transmitter accuracy is a percentage of the sensor full range. Choose the 4-20mA level transmitter with a measuring range according to depth of source tank.

Set to Operational mode 04, four additional parameters are available. The installer must program the controller with the correct values. The values are in centimetres

- | | |
|---|---------------|
| 1) Level transmitter full measuring range | Parameter 033 |
| 2) Pump cut-out/stop liquid level depth value | Parameter 034 |
| 3) Pump 1 cut-in/start liquid level depth value | Parameter 035 |
| 4) Pump 2 cut-in/start liquid level depth value | Parameter 036 |
| 5) Overflow alarm liquid level depth value | Parameter 037 |

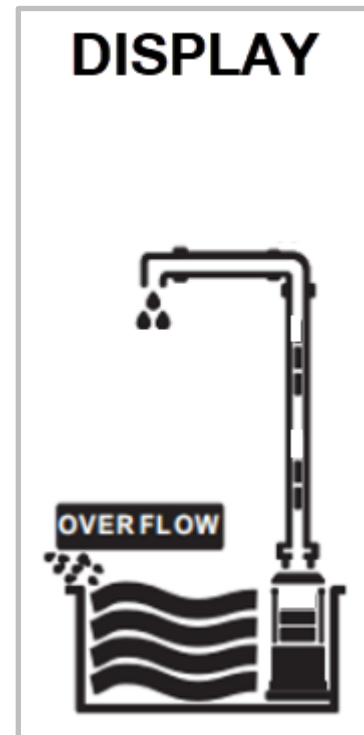

Example:

Full measuring range:	200 cm
Overflow alarm depth value:	150 cm
Pump cut-in (start) depth values:	20 cm and 40cm
Pump cut-out (stop) depth value:	10 cm

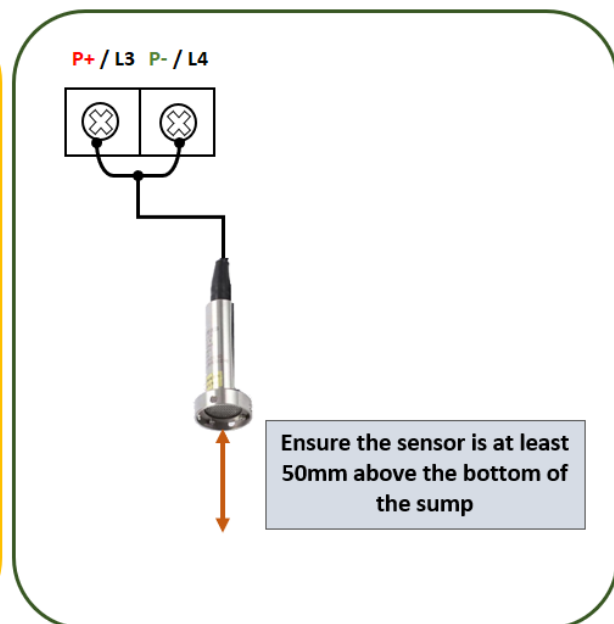
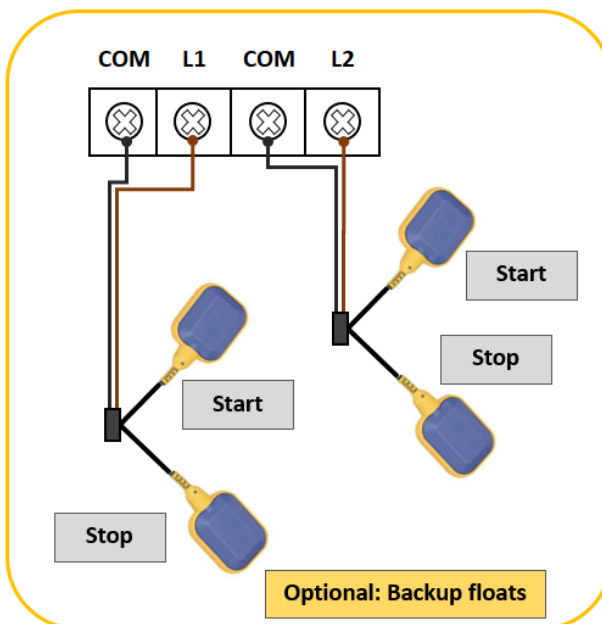

Set in drainage mode, if the controller detects the pump has not run for the time period value in Parameter 009 (default 96 hrs), the pump will start and run briefly to prevent the hydraulic components seizing.

17. Quick guide: Pressure Boosting 4-20mA

Parameter 003 = **06** **4-20mA input.**

Pump On/Off operation is controlled via a 4-20mA pressure transducer connected to P+ (L3) and P- (L4)

Additional (optional) switched run/no run protection can be fitted at the source Com, L1 and L2

Set to Operational mode 05, four additional parameters are available.

The installer must program the controller with the correct values. All values are in Bar

- | | |
|---|---------------|
| 1) Pressure sensor full measuring range | Parameter 029 |
| 2) Pump cut-out/stop pressure | Parameter 030 |
| 3) Pump cut-in/start pressure value | Parameter 031 |
| 4) Over pressure alarm value | Parameter 032 |

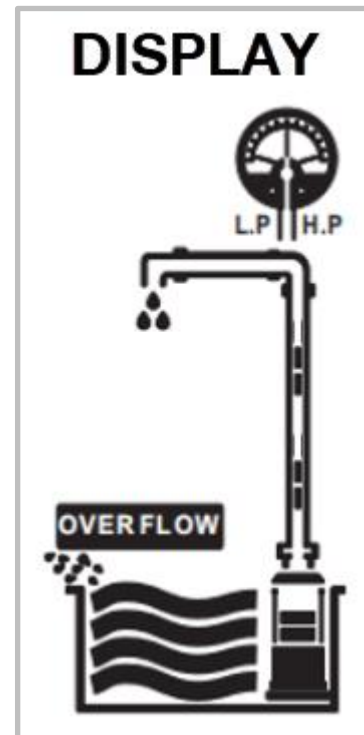

Example:

Full measuring range:	10 bar
Pump cut-in (start) pressure:	2 bar
Pump cut-out (stop) pressure:	4 bar
Over pressure alarm value:	8 bar

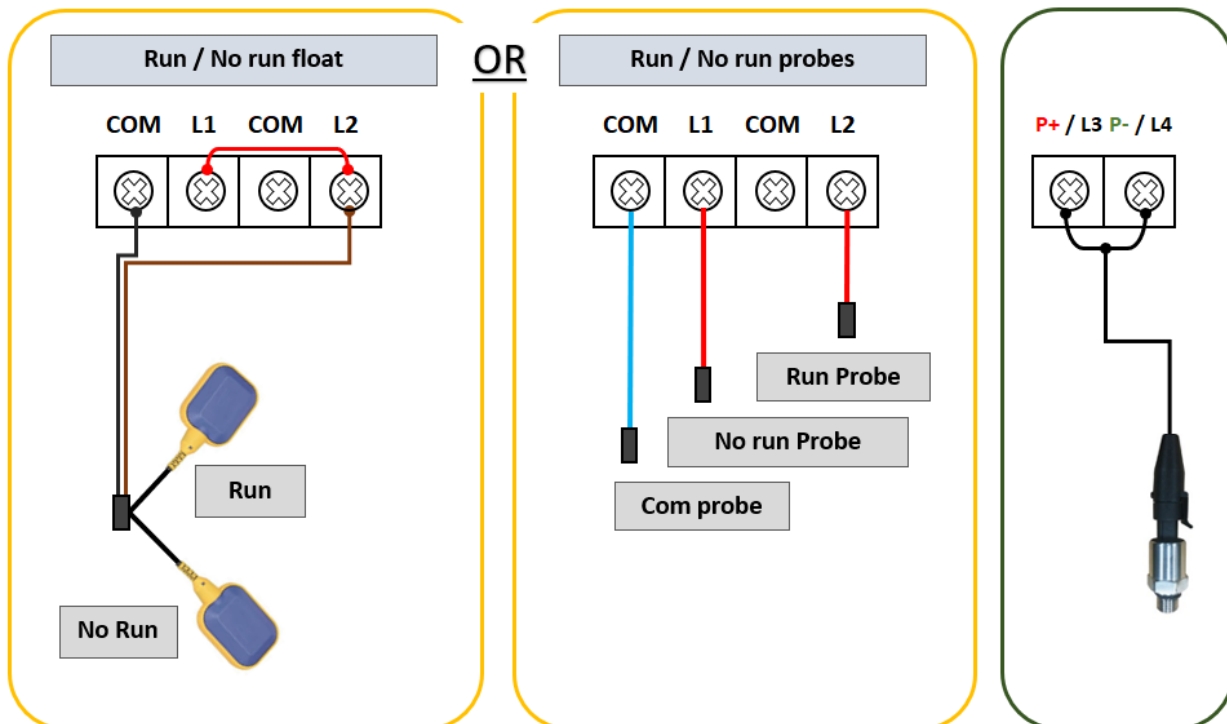

Additional control and protection parameters can be employed in Boosting mode. See Pg 19

18. Quick guide: Transfer – source/destination control 4-20mA

Parameter 003 = **07** 4-20mA input.



Transmitter accuracy is a percentage of the sensor full range. Choose the 4-20mA level transmitter with a measuring range according to depth of source tank.

The destination control (level sensor) provides a request to start based on liquid level.

A float switch or probes at the source controls whether the pump will run or not, depending on the liquid level.

Set to Operational mode 06, five additional parameters are available. The installer must program the controller with the correct values. The values are in centimetres

- 1) Level transmitter full measuring range
- 2) Overflow alarm liquid level depth
- 3) Pump 1 cut-in/start liquid level depth
- 4) Pump 2 cut-in/start liquid level depth
- 5) Pump cut-out/stop liquid level depth

- Parameter 033
- Parameter 037
- Parameter 035
- Parameter 036
- Parameter 034

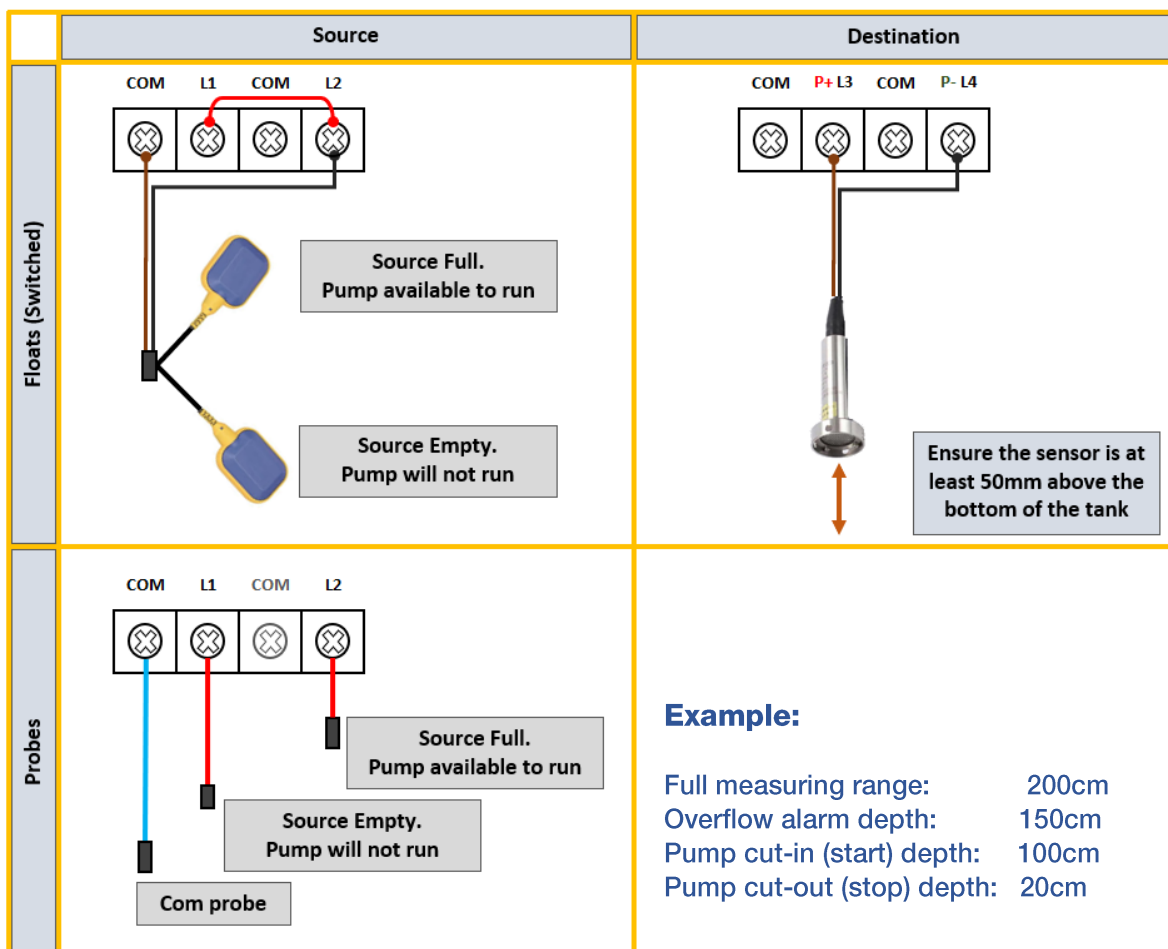
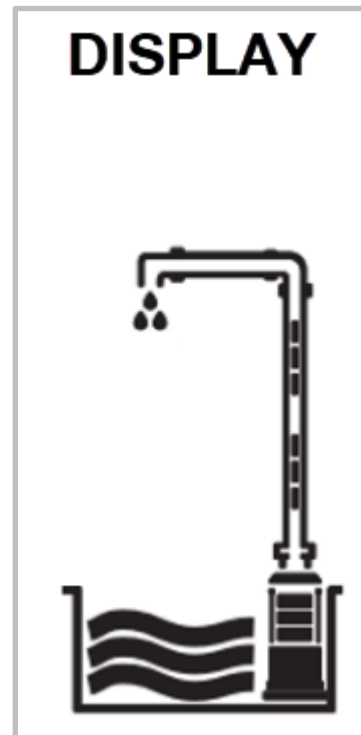

19. Backup power supply

In some regions battery backup for the high-level alarm is mandated.

Connecting a 24v battery pack will maintain the alarm and control circuit in case of a mains power failure.

When mains power falls, the unit will display in input voltage (24V) and the Under-Voltage warning message will display on the screen. The pump will not attempt to run, the backup power supply is only to ensure the Hi-Level alarm is able to function for as long as the backup battery maintains its output

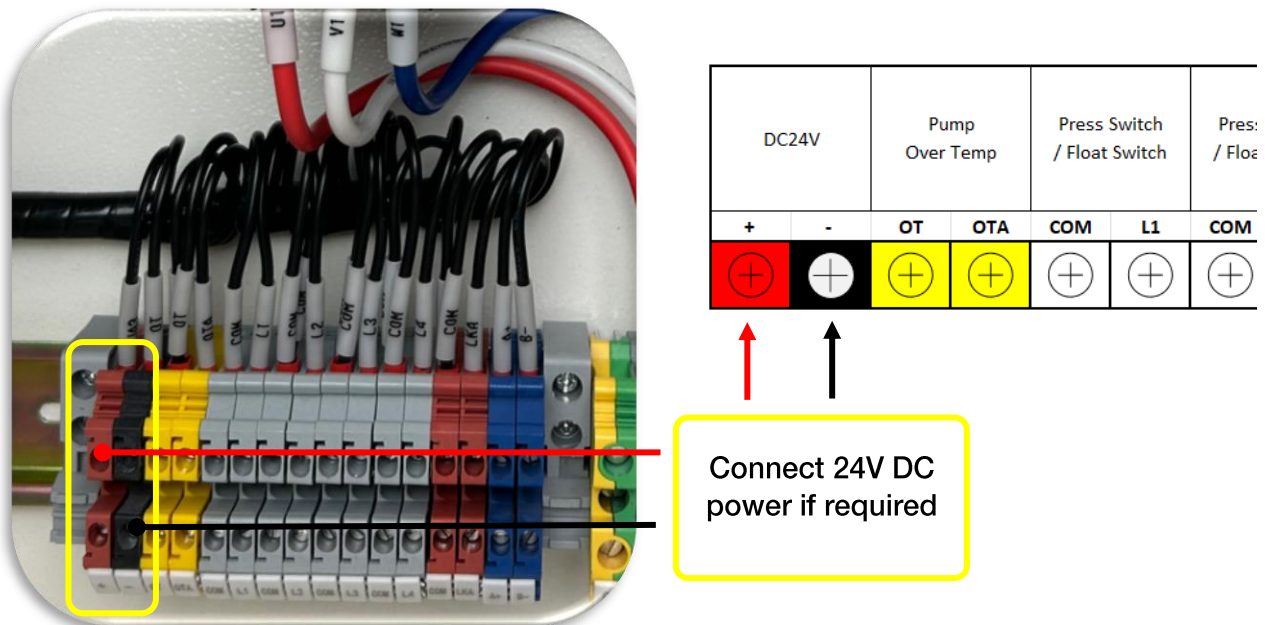

20. External Alarm

The PLC has an inbuilt audible alarm.

The External Audible / Visual alarm light supplied with the nXt DPC Pro panel receives pulses of 24V DC power from the PLC (JB2, JB3).







An additional 24V DC external, remote alarm can be fitted and wired in parallel. [PN 811785](#)



21. Fault Messages

Fault Message	Possible Cause	Potential Solutions
UNDER V	The actual running voltage is lower than the calibrated voltage parameter 027 . The pump is in an under-voltage protection state	The controller will attempt to restart the pump every 5 minutes until line voltage is restored to normal If this fault occurs repeatedly, report low line voltage to the power supply company
OVER V	The actual running voltage is higher than the calibrated voltage parameter 028 . The pump is in over-voltage protection state	The controller will attempt to restart the pump every 5 minutes until line voltage is restored to normal If this fault occurs repeatedly, report high line voltage to the power supply company
PUMP STALLED	The pump motor running amperage has exceeded the normal (calibrated) running amperage by more than parameter 025 (default value 180%) This could be due to physical jamming or a mechanical issue. If the pump stalled error occurs repeatedly at commissioning check the controller rating is matched to the pump	Pump Stalled is a 'critical error' and will not automatically reset. Isolate the power supply and inspect the pump for anything which has caused the sudden increase in load
OVER LOAD	Pump motor running amperage exceeds the normal (calibrated) running amperage by more than parameter 024 (default value 130%)	Isolate the power supply and inspect the pump for anything which is causing the pump to draw more amperage than the initial calibration value
UNDER LOAD	Pump motor running amperage is less than the normal (calibrated) running amperage by more than parameter 023 (default value 75%)	Under-load is sometimes referred to as Dry-run protection as a pump motor will draw less current when there is no load.
OPEN PHASE	The power supply has lost a phase.	Check fuses and wiring.
PUMP NO CALIBRATION	Calibration not complete	Check the calibration Parameter 021, 022
OVER TEMP Parameter 006 ON	The temperature in the pump motor is high causing the thermal switch (if fitted) to operate	Investigate the cause of the overheating.
PUMP LEAKAGE	The pump moisture sensor has detected moisture inside the pump body	Service or replace pump

22. Accessories

Image	Description	Part #
	Capacitance Probe	805321
	4-20mA pressure transducer 1MPA	802680
	4-20mA level transducer 2m	804528
	SK12(5M) H05 10 amp SK12(10M) H05 10 amp SK12(20M) H05 10 amp SK12(30M) H05 10 amp FSK1 (5m) H07 10 amp FSK1 (10m) H07 16 amp FSK1-20 (20m) H07 16 amp	700965 700962 700963 700964 809941 700610 700611
	FSK1.1(10m) H07 10 amp	801125
	Float switch counter-weight	700967
	Pressure switch (NC) 6 bar Pressure switch (NC) 12 bar Reverse acting pressure switch (NO) 5.5 bar Reverse acting pressure switch (NO) 10 bar	701440 701380 809863 809864

23. Warranties – Terms and Conditions

This warranty is given in addition to the consumer guarantees found within the Australian Competition and Consumer Act 2010 (Cth) for goods purchased in Australia and the Consumer Guarantees Act 1993 NZ for goods purchased in New Zealand:



1) White International Pty Ltd / White International NZ Ltd (White International) warrant that all products distributed are free from defects in workmanship and materials, for their provided warranty period as indicated on the top or opposite side of this document. Subject to the conditions of the warranty, White International will repair any defective products free of charge at the premises of our authorised service agents throughout Australia and New Zealand if a defect in the product appears during the warranty period. If you believe that you have purchased a defective product and wish to make a claim under this warranty, contact us on our Sales Hotline on 1300 783 601, or send your claim to our postal address or fax line below and we will advise you as to how next to proceed. You will be required to supply a copy of your proof of purchase to make a claim under this warranty.

2) This warranty excludes transportation costs to and from White International or its appointed service agents and excludes defects due to non-compliance with installation instructions, neglect or misuse, inadequate protection against the elements, low voltage or use or operation for purposes other than those for which they were designed. For further information regarding the suitability of your intended application contact us on our Sales Hotline on 1300 783 601. If you make an invalid claim under this warranty, the original product will be sent back to you unrepai red.

3) This warranty refers only to products sold after the 1st January 2012, and is not transferable to another product type and only applies to the original owner, purchaser or end user, and is in addition to the consumer guarantees found within the Competition and Consumer Act 2010 (Cth) for goods purchased in Australia and the Consumer Guarantees Act 1993 (NZ) for goods purchased in New Zealand.

4) Our goods come with guarantees that cannot be excluded under the Australian Consumer Law. You are entitled to a replacement or refund for a major failure and for compensation for any other reasonably foreseeable loss or damage. You are also entitled to have the goods repaired or replaced if the goods fail to be of acceptable quality and the failure does not amount to a major failure. 2 YEAR WARRANTY

5) To the fullest extent permitted by law, White International excludes its liability for all other conditions or warranties which would or might otherwise be implied at law. To the fullest extent permitted by law, White International's liability under this warranty and any other conditions, guarantees or warranties at law that cannot be excluded, including those in the Competition and Consumer Act 2010 (Cth), is expressly limited to: (a) in the case of products, the replacement of the product or the supply of equivalent product, the payment of the cost of replacing the product or of acquiring an equivalent product or the repair of the product or payment of the cost of having the product repaired, is at the discretion of White International or a 3rd party tribunal elected under the Competition and Consumer Act 2010 (Cth) for goods purchased in Australia and the Consumer Guarantees Act 1993 (NZ) for goods purchased in New Zealand; and

6) To the fullest extent permitted by law, this warranty supersedes all other warranties attached to the product or its packaging.

7) In the case of services, supplying the services again or the payment of the cost of having the services supplied again, is at the discretion of White International or a 3rd party tribunal elected under the Competition and Consumer Act 2010 (Cth) for goods purchased in Australia and the Consumer Guarantees Act 1993 (NZ) for goods purchased in New Zealand. 8) Our warranty commences from the date of purchase of the above-mentioned pumps. Proof of purchase is required before consideration under warranty is given.

Record your date of purchase in the space below and retain this copy for your records.

Date of Purchase**Model Purchased**



www.whiteint.com.au

1300 783 601

www.whiteint.co.nz

0800 509 506

Please always refer to our website for further technical information & new product innovations

Disclaimer: Every effort has been made to publish the correct information in this manual. No responsibility will be taken for errors, omissions or changes in product specifications.

© 2024 Copyright White International Pty Ltd

TM ® - WARNING: Please be aware that various brands & products depicted within this document are subject to trademark, patent or design registrations. Infringement of any intellectual property contained within this document without express written authority by the appropriate intellectual property holder may result in further legal action to be taken. For any queries regarding use of the contained information please feel free to contact White International Pty Ltd.